

INNOVAIR
Intelligent Fan Convectors – IQL Controller
SIZE 1 & 2 Units

**INSTALLATION, OPERATION &
MAINTENANCE INSTRUCTIONS**

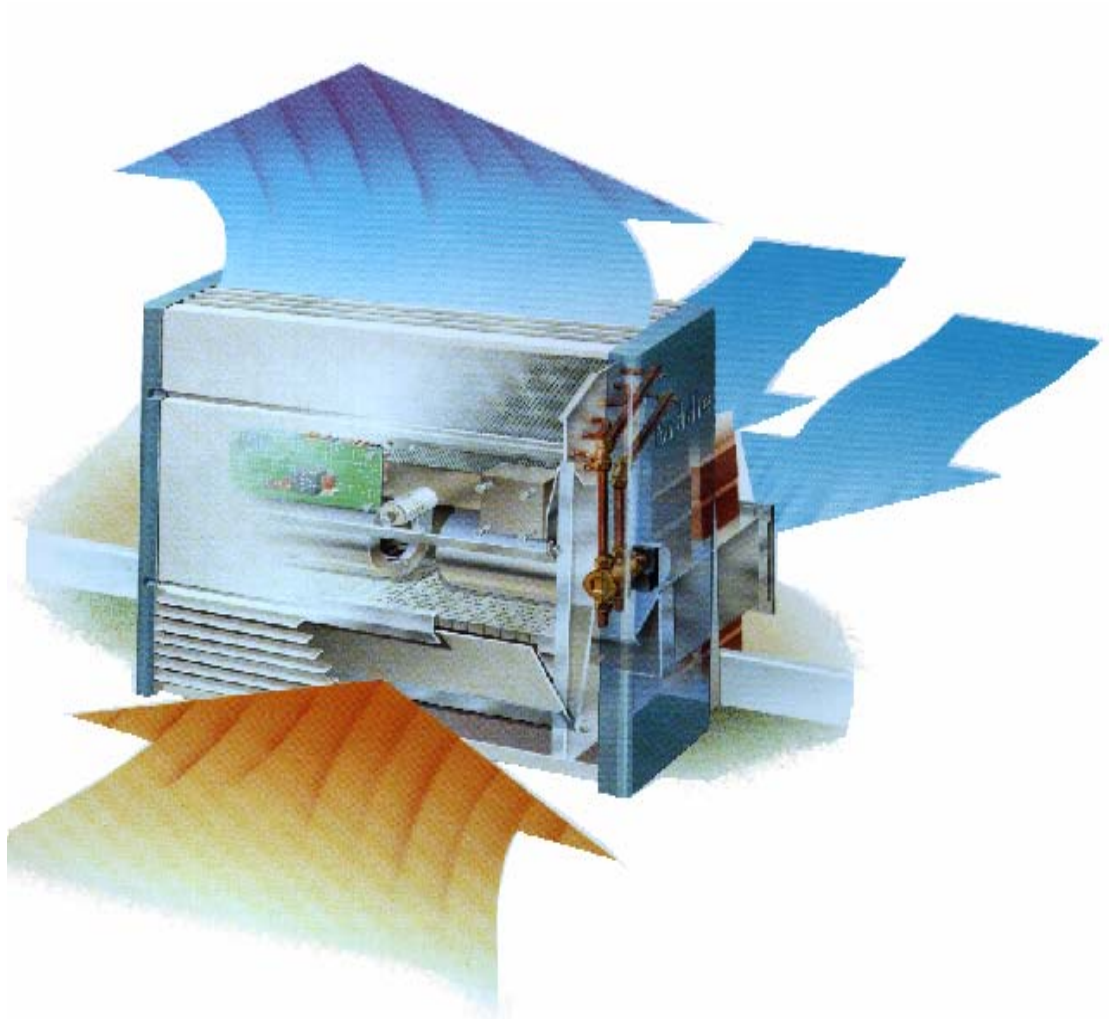

CONTENTS

GENERAL INFORMATION

Important.....	Page 3
Dimensions & Weights.....	Page 3
Ductwork Connections.....	Page 4
Fixing Crs & Coil Connections.....	Page 5

INSTALLATION

Stages Involved.....	Pages 6 to 8
Connecting the Unit to Mains Power.....	Page 9
Customer Connection Centre Diagram – Water heated units...	Page 10
Customer Connection Centre Diagram – Electrically heated Units.....	Page 11 TBA
Connecting the Remote Control Pad to the Unit.....	Page 12
Connecting Units as Master/Slave orSlave/Slave Arrangement.....	Page 12
Connecting the Unit to a BMS.....	Page 13
Connecting the Unit to a Timer Clock or PIR.....	Page 13
Connecting the Unit to an Extract System.....	Page 14
Connecting the Unit to a Biddle CO ₂ Sensor.....	Page 15

OPERATION

Control Pad.....	Pages 16, 17 & 18
------------------	-------------------

MAINTENANCE

Access Panel.....	Page 19
End Panels.....	Page 19
Filter.....	Page 19
Fans & Motors.....	Page 19
Heating Coil.....	Page 19
Damper & Actuator.....	Page 19
Casing.....	Page 19

GENERAL INFORMATION

IMPORTANT!

IT IS ESSENTIAL TO ISOLATE THE UNIT FROM THE ELECTRICAL SUPPLY AND THE CONTROL CIRCUIT POWER SUPPLY BEFORE CARRYING OUT ANY MAINTENANCE, AND TO ENSURE THAT THE POWER CANNOT BE ACCIDENTLY RESTORED BY UNAUTHORISED PERSONNEL.

DIMENSIONS & WEIGHTS

	Size 1		Size 2	
	Cased	Recessed	Cased	Recessed
Width	735mm	633mm	1238mm	1136mm
Depth	245mm	245mm	245mm	245mm
Height	680mm	680mm	680mm	680mm
Weight	28kg	26kg	41kg	39kg

Figure 1a

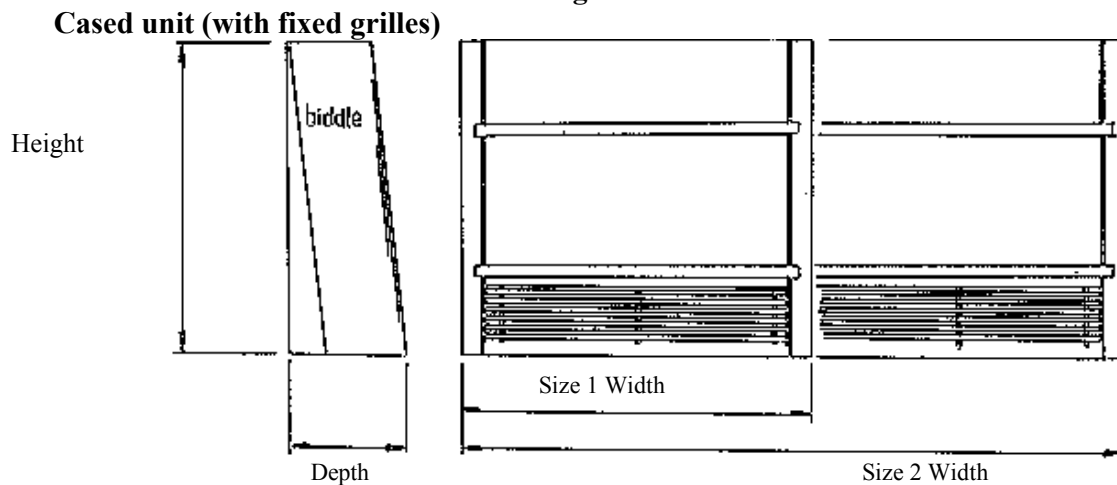
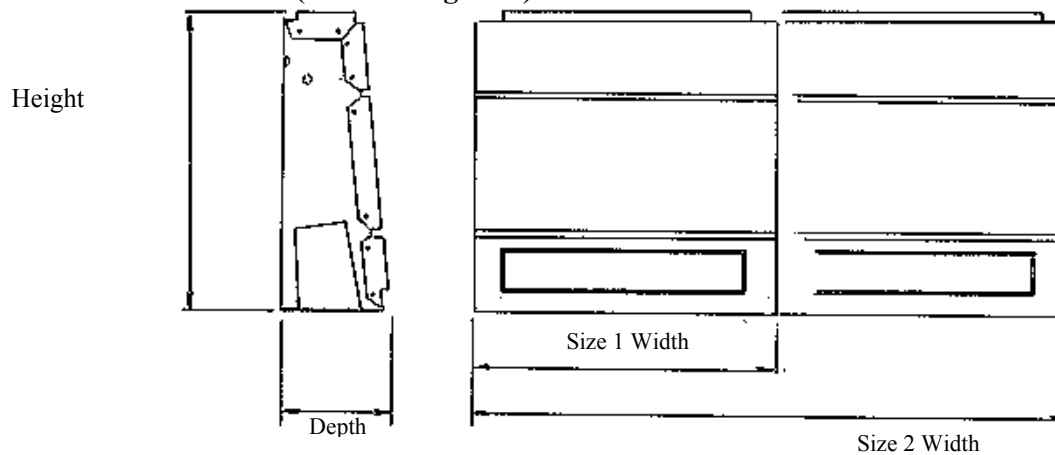

Figure 1b

Recessed/Chassis unit (with loose grilles)



FRESH AIR INLET SPIGOTS (BACK OR BOTTOM ENTRY)

Rectangular FAI Spigot & Spigot Plate	Spigot Width (mm)	Spigot Height (mm)	Spigot Depth (mm)	
Size 1	403	127	25	
Size 2	906	127	25	
Circular FAI Spigots & Spigot Plate	Pitch Separation	Spigot Diameter (mm)	Spigot Depth (mm)	Number of Spigots
Size 1	1 x 236	150	35	2
Size 2	3 x 246	150	35	4

DISCHARGE SPIGOTS (ON RECESSED/CHASSIS UNITS ONLY)

Ceiling or Wall Mounted Unit Rectangular Discharge Spigot Casing style WL2 or CL2 (recommended)	Spigot Width (mm)	Spigot Height (mm)	Spigot Depth (mm)	
Size 1	632	164.5	25	
Size 2	1135	164.5	25	
Ceiling or Wall Mounted Unit Rectangular Discharge Spigot Casing style WL1 or CL1 (not recommended)	Spigot Width (mm)	Spigot Height (mm)	Spigot Depth (mm)	
Size 1	632	164.5	25	
Size 2	1135	164.5	25	
Ceiling or Wall Mounted Unit Circular Discharge Spigots All styles	Pitch Separation	Spigot Diameter (mm)	Spigot Depth (mm)	Number of Spigots
Size 1	2 x 204.5	150	35	3
Size 2	4 x 218.0	150	35	5

RETURN AIR SPIGOTS (ON RECESSED/CHASSIS UNITS ONLY)

Ceiling or Wall Mounted Unit Rectangular Return Air Spigot	Spigot Width (mm)	Spigot Height (mm)	Spigot Depth (mm)	
Size 1	632	164.5	25	
Size 2	1135	164.5	25	
Ceiling or Wall Mounted Unit Circular Return Air Spigots	Pitch Separation	Spigot Diameter (mm)	Spigot Depth (mm)	Number of Spigots
Size 1	2 x 204.5	150	35	3
Size 2	4 x 218.0	150	35	5

INSTALLATION

STAGES INVOLVED

Figures 3 to 8 show how the unit is installed and assembled.

Take care not to damage components and accessories when handling them.

Before installing the unit check that there will be adequate **access space** for maintenance (300mm each side).

The approximate amount of time needed to install the unit is **half a day**, plus the time needed to make the fresh air duct hole in the building.

Remember that in order to get heating on water heated units, all the air must be bled from the system including the coil in the unit.

Figure 3

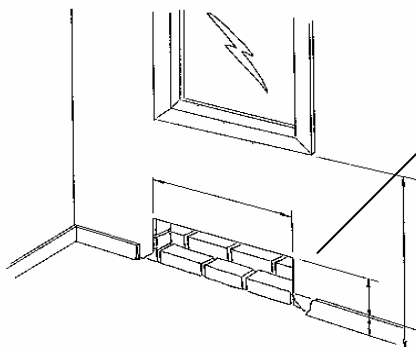

	Width	Height
Size 1	412 mm	134 mm
Size 2	915 mm	134 mm

Figure 4

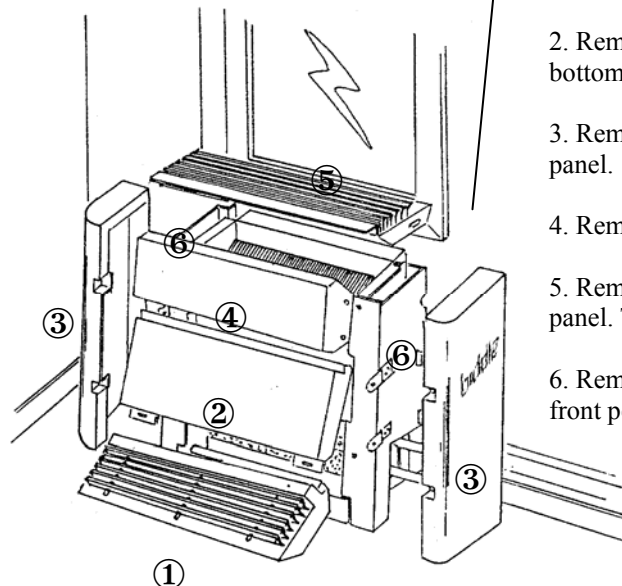

Remove casing in following order:

1. Remove recirc grille access panel. Sharp pull upwards and then out.
2. Remove front access panel. Two screws at bottom.
3. Remove plastic end panels. Two screws per panel.
4. Remove coil access panel. Four Screws.
5. Remove discharge grille and discharge access panel. Two screws.
6. Remove metal side panels. Two screws at front per panel.

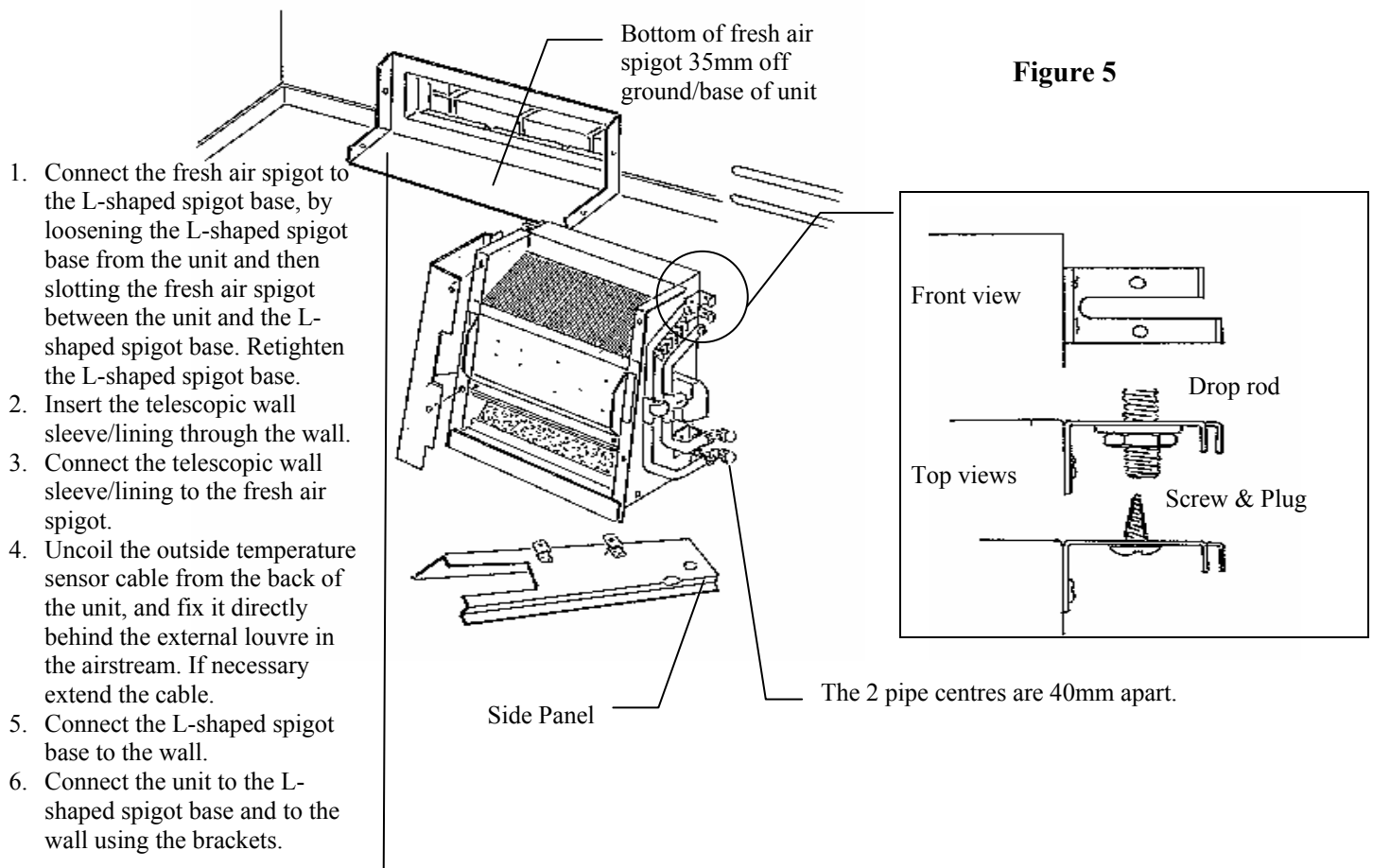

Figure 5

Note: If installing **re-circulation** units, simply connect the unit to the wall and do **not** uncoil or move the outside temperature sensor.

Connect unit to mains power, remembering Size 2 electric heated units require a 3-phase supply (refer to pages 9 to 11).

Connect unit to remote control pad (refer to page 12).

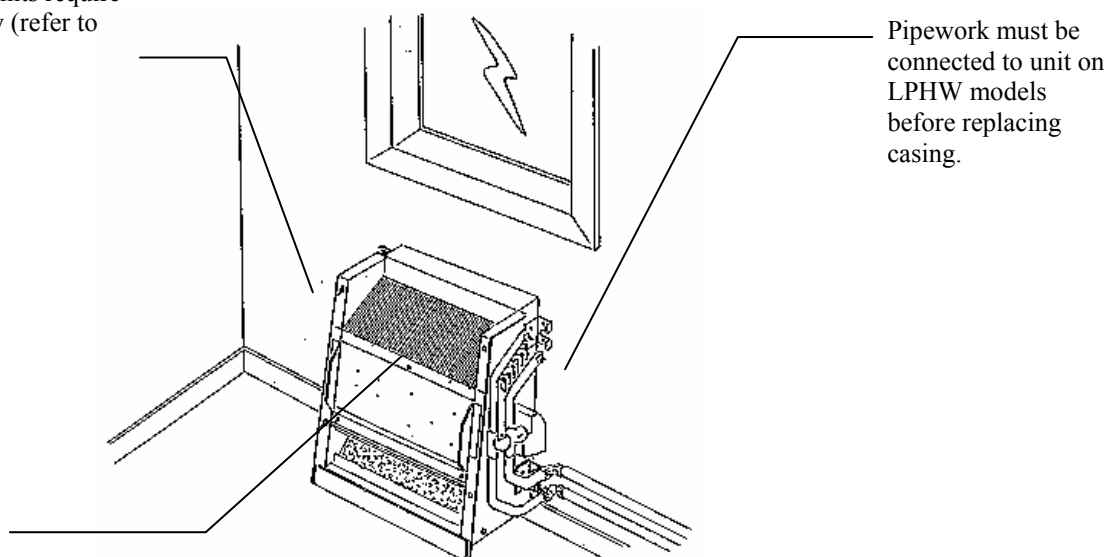

Figure 6

Figure 7

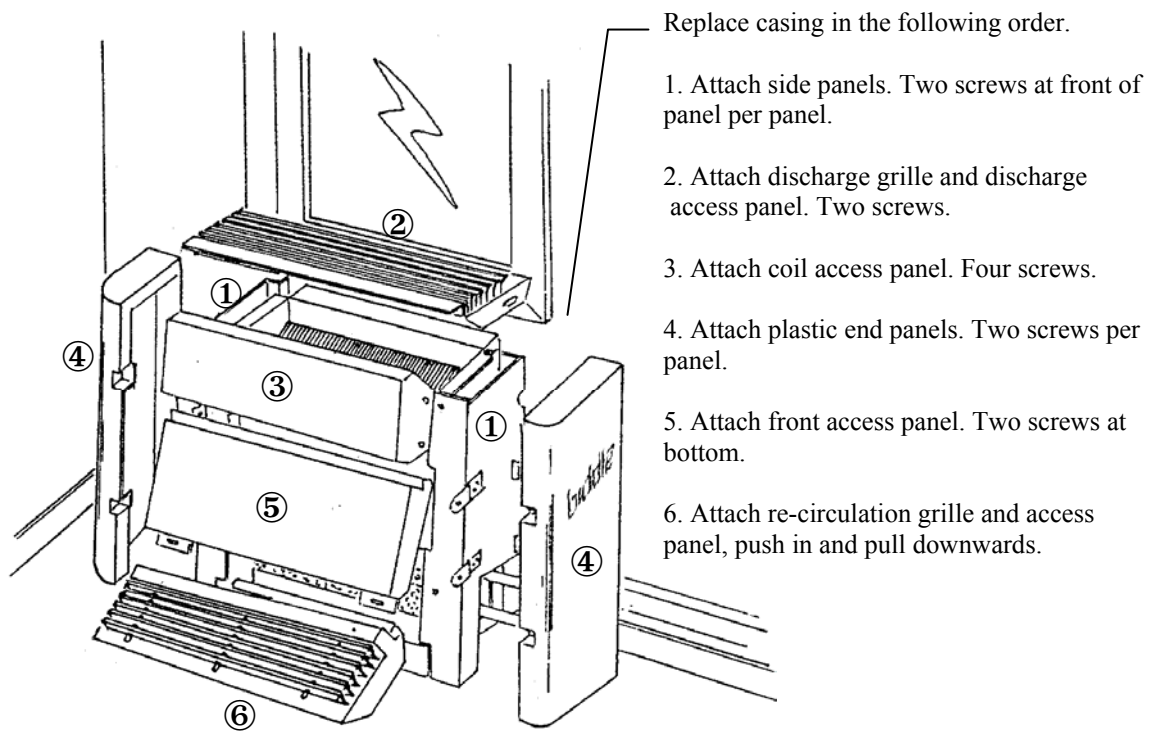
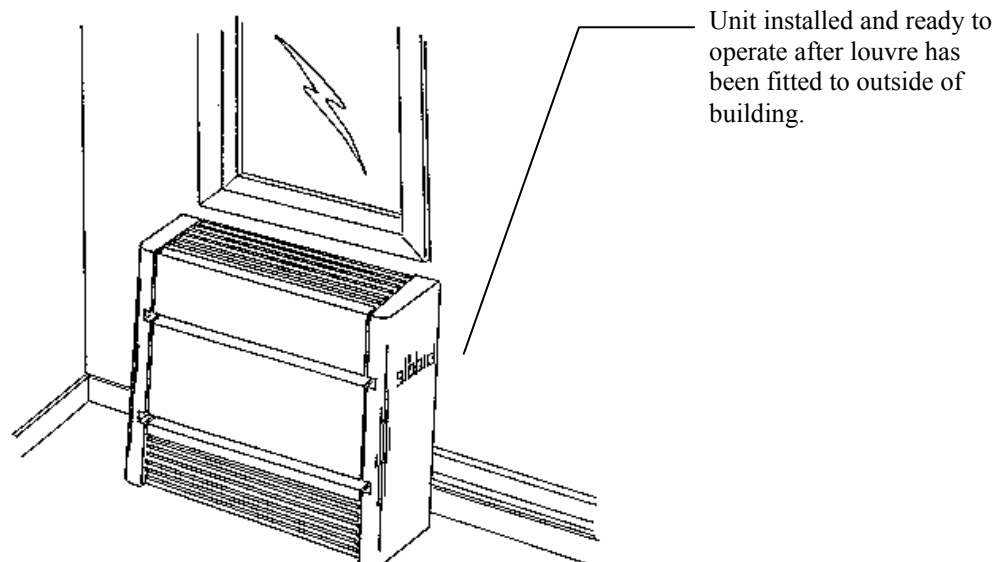

Figure 8



CONNECTING THE UNIT TO MAINS POWER

The recommended mains supply cables for Innovair are:

- Size 1 & 2 water heated units, 3-core mains cable (Cu/PVC/PVC) size 1mm²
- Size 1 electric heated units, 3-core mains cable (Cu/PVC/PVC) size 1.5mm²
- Size 2 electric heated units, 4-core steel wire armoured cable (Cu/PVC/PVC/SWA/PVC) size 1.5mm² or single core conduit cable (Cu/PVC) size 1.5mm², 3 lives/neutral/earth with suitable size 20mm conduit and fittings.

		Mains Supply	Running Current (Amps)	Starting Current (Amps)
Water Heated	Size 1	230V/~50Hz	1.0	3.0
	Size 2	230V/~50Hz	2.0	6.0
Electric Heated	Size 1	230V/~50Hz	13.0	3.0
	Size 2	400V/3N~/50Hz	9.0 per phase	6.0

The electric control panel should be accessed by unscrewing the securing screw(s) and lowering the panel into a horizontal position.

Size 1 (Water & Electric), Size 2 (Water) Thread the mains power cable through the cable gland on the RHS. Wire to terminals L N E on the connection centre PCB located at the LH end of the electric control panel. See diagram on page 10. Use cable ties provided to secure cables and ensure they are not trapped when hinged panel is replaced.

Size 2 (Electric). Thread mains power cable through cable gland plate at LHS of the unit and wire to terminals L₁ L₂ L₃ N and Earth stud at bottom of EMC filter. See wiring diagram.

Note that **Size 2 electric heated units require a 3-phase supply.**

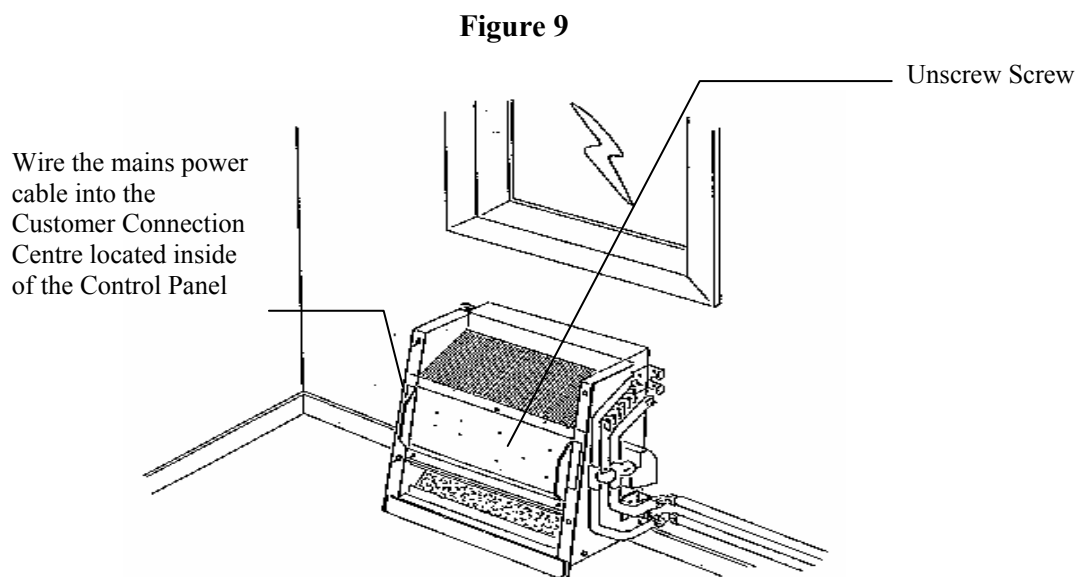

WIRING DIAGRAM – CUSTOMER CONNECTION CENTRE

Only for Size 1 & 2 Water and Size 1 electric

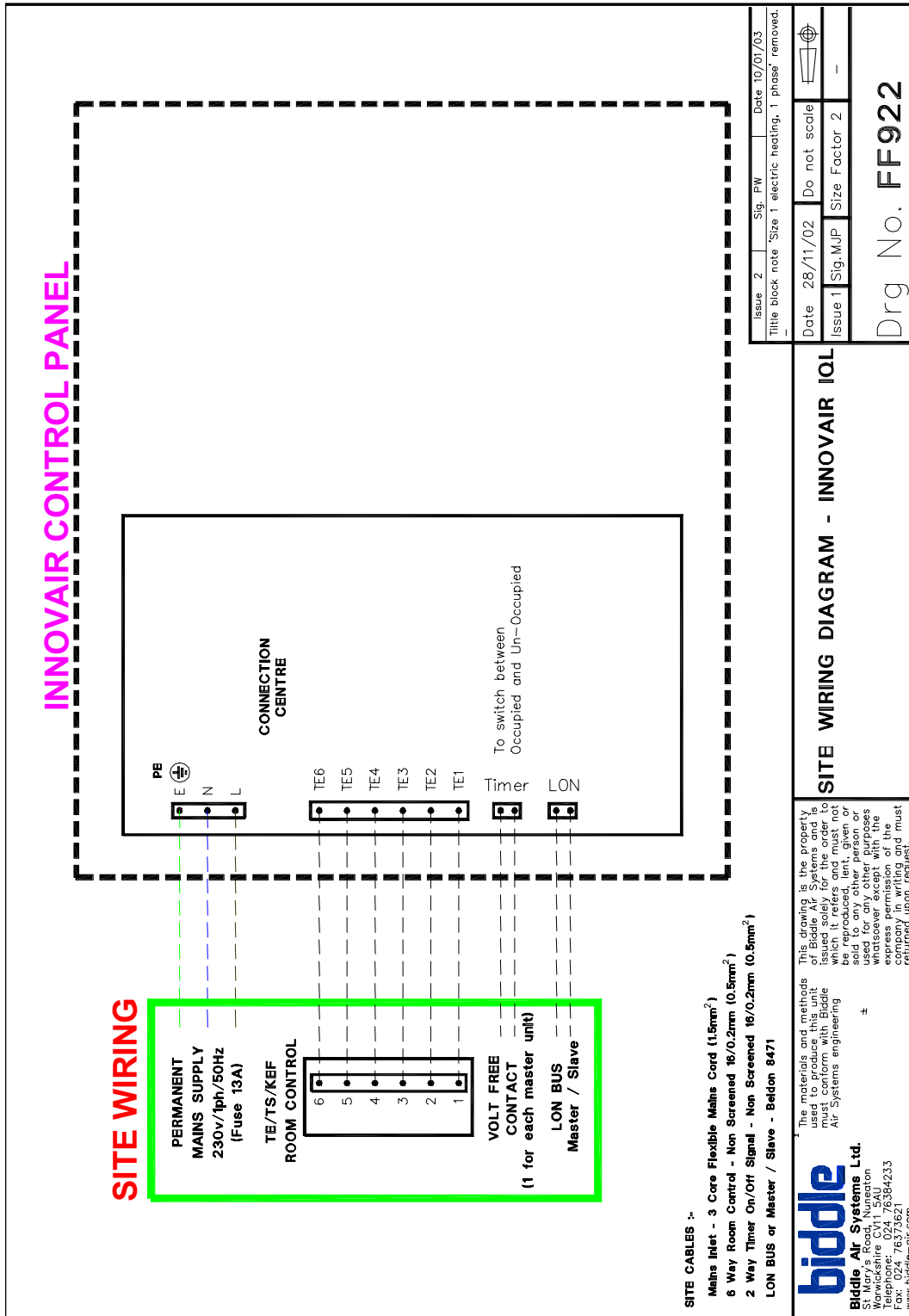

**WIRING DIAGRAM – CUSTOMER CONNECTION CENTRE
Size 2 Electric units only.**

CONNECTING THE REMOTE CONTROL PAD TO THE UNIT.

The remote room controller supplied with the unit should be connected via the customer connection centre at the LHS of the control panel using Non Screened 16/0.2mm (0.5mm²) cable. Cable ties and cable glands are provided to secure cables and ensure that they are not trapped when the hinged cover is replaced.

THIS CONNECTION IS VOLTAGE FREE AND SHOULD NOT BE CONNECTED TO ANY OTHER VOLTAGE SOURCE.

The Model TE/TS/KEF for manual heating & ventilation adjustment requires 6 cores connected to TE1 – TE6.

The Model TE/TS/K for manual heating & automatic / no ventilation adjustment requires 3 cores connected to TE1, TE2 & TE3 only.

Cables must be connected to the both the customer connection centre and remote control pad using the identically numbered terminal blocks.

See Customer connection centre diagram and installation instructions supplied with the control pad for details.

CONNECTING UNITS AS MASTER/SLAVE OR SLAVE/SLAVE ARRANGEMENT

Master / Slave connection is made via the LON terminal on the Customer Connection Centre. Connection should be made using 2 core Beldon 8471 cable. Cable ties and cable glands are provided to secure cables and ensure that they are not trapped when the hinged cover is replaced.

THIS CONNECTION IS VOLTAGE FREE AND SHOULD NOT BE CONNECTED TO ANY OTHER VOLTAGE SOURCE.

Cable should be connected from the LON terminal block on the master unit to the LON terminal block on the first slave unit and so on to the other slave units.

See Customer connection centre diagram for details.

There is no limit to the number of slave units that can be connected to the master unit so long as the Beldon cable does not exceed 100m in length.

CONNECTING THE UNIT TO A BMS

BMS connection is made via the 'LON' terminal on the Customer Connection Centre. Connection should be made using 2 core Beldon 8471 cable. Cable ties and cable glands are provided to secure cables and ensure that they are not trapped when the hinged cover is replaced.

THIS CONNECTION IS VOLTAGE FREE AND SHOULD NOT BE CONNECTED TO ANY OTHER VOLTAGE SOURCE.

BMS control enables supervisor software to switch units on and off, change software knob settings on the unit, Trend log etc. The basic internal strategy of the unit cannot be amended.

See Customer connection centre diagram for details.

CONNECTING THE UNIT TO A TIMER CLOCK OR P.I.R. Sensor.

Your timer clock or P.I.R. Sensor should be connected to the unit via the customer connection centre using 2 core non screened 16/0.2mm (0.5mm²). Cable ties and cable glands are provided to ensure that the cables are not trapped when the hinged cover is replaced.

Cable should be connected to the 'TIMER' terminal block.

There must be a separate volt free contact for each Innovair connected to the timer clock or P.I.R. sensor.

For multiple installations the timer clock or P.I.R. sensor should operate multiple pole relays, so that each Innovair has its own separate pole/control.

THIS CONNECTION IS VOLTAGE FREE AND SHOULD NOT BE CONNECTED TO ANY OTHER VOLTAGE SOURCE.

See Customer connection centre diagram for details.

CONNECTING THE UNIT TO AN EXTRACT &/OR SUPPLY FAN SYSTEM (SINGLE PHASE SUPPLY & RUNNING CURRENT NO GREATER THAN 8A)

Where an extract fan or additional supply fan is required in the system, the on/off control can be enabled via the Innovair units. This is achieved using either a delay on or delay off relay controlled via the IQL .

The relay can be provided (Optional extra) mounted and wired to the side of the Innovair unit for connection on site using 3 core mains cable size 1.0mm² cable. The relays can activate the external fans when the unit is operating in standard ventilation mode, in free cooling mode and during night cooling mode.

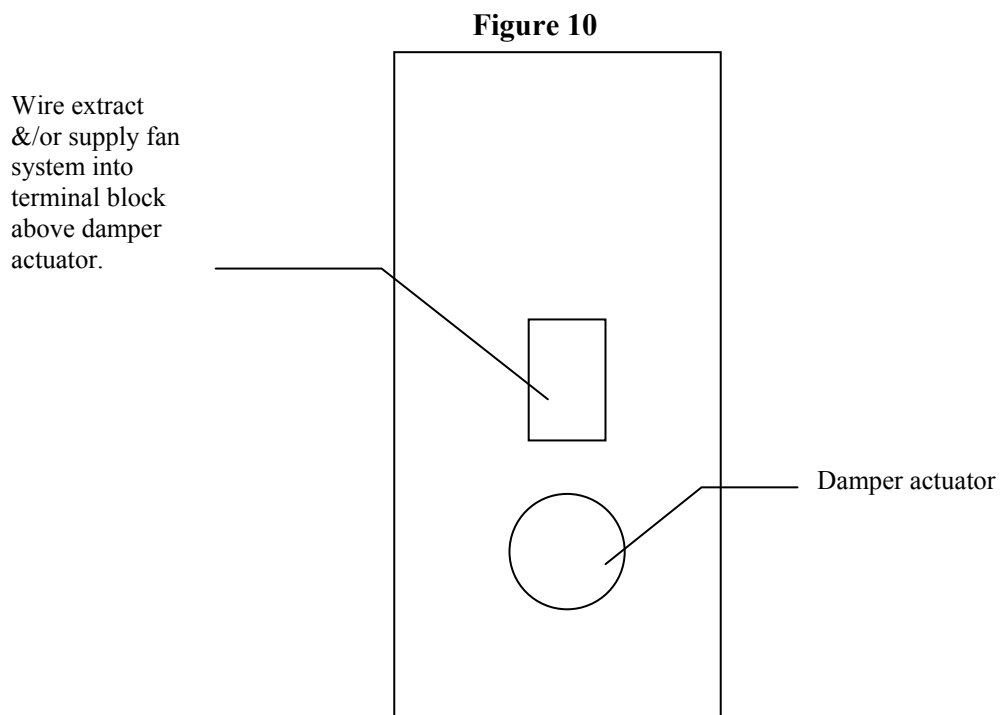

CONNECTING THE UNIT TO A BIDDLE CO₂ SENSOR

The Biddle supplied CO₂ sensor and connection equipment is normally for use on Stand Alone Innovair units and not the BMS type. Each unit is provided with the externally wall mounted sensor and connected to built-in volt sensitive relays and control equipment.

Where more than 1 unit is provided in a single controlled space, then only the master unit needs to be controlled via the CO₂ sensor. For Master / Slave connection see page 12.

THIS CONNECTION IS VOLTAGE FREE AND SHOULD NOT BE CONNECTED TO ANY OTHER VOLTAGE SOURCE.

Terminal block connections for the CO₂ sensor are fitted within the Innovair units inside the electrical control panel on the RHS.

Cable should be:

Non Screened 16/0.2mm (0.5mm²) for connections G+ & G0 (24v Supply)

Screened 16/0.2mm (0.5mm²) for connections OUT1 & M (0 – 10v Signal)

See wiring diagram supplied with units for more information.

OPERATION – Manual / Stand Alone Type

Control Pad – Heat and Ventilation

Figure 11

Controller type: TE/TS/KEF for manual operation of Temperature & Ventilation.
Also incorporates a room air temperature sensor

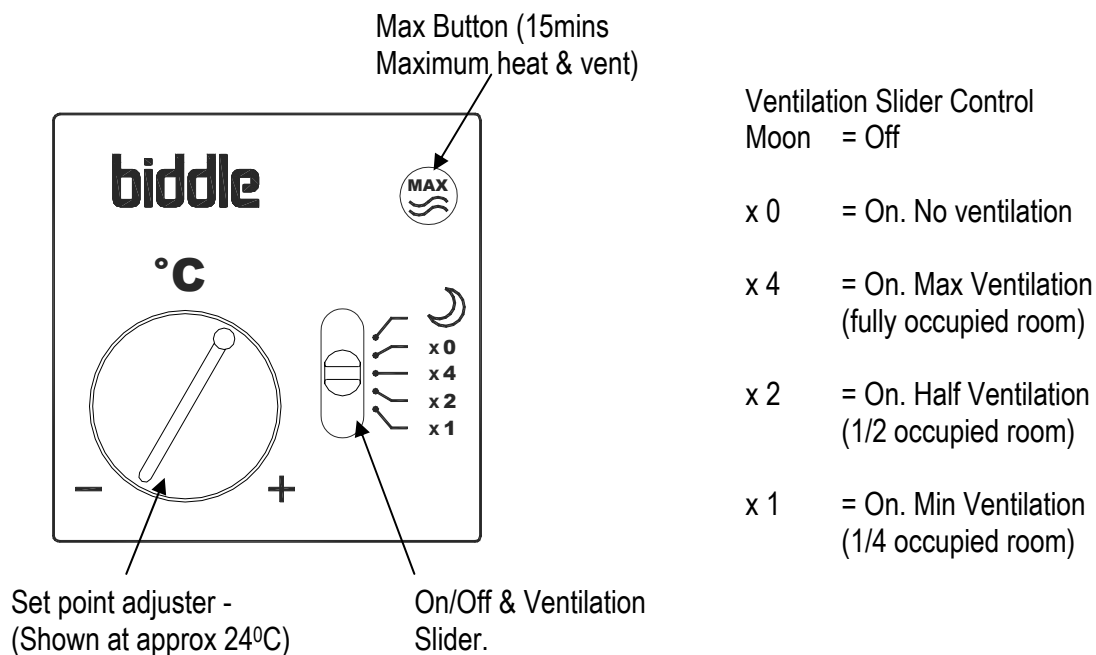

Each new day – Reset the ventilation control to the desired level as the unit will automatically default to minimum (x 1) to save energy.

DO NOT SWITCH UNIT OFF AT THE MAINS except in case of emergency

Unit Functionality:

When the slider is set in the top position indicated by the ‘Moon’ symbol the unit is effectively switched to OFF or in ‘**unoccupied**’ **set-back** mode.

When the slider is set to any other position the unit will be in the ON position or in **normal ‘occupied’ operating** mode.

Normal ‘occupied’ operating mode.

In this mode the unit is operated to firstly control the level of fresh air ventilation (by cycling of the damper), and secondly to satisfy set point temperature requirements (by heating or free cooling).

Unoccupied' set-back mode.

In this mode the unit operates to satisfy the set back temperature or 'night time cooling requirement only.

During 'occupied' operating room temperature is controlled by the set-point adjuster, which can be rotated between the 15°C and the 30°C settings.

Ventilation level is controlled by moving the slider to X0, X1, X2, & X4 positions.

X 0 position gives heating and no ventilation.

X 1 position gives heating and $\frac{1}{4}$ ventilation or minimum occupancy.

X 2 position gives heating and $\frac{1}{2}$ ventilation or $\frac{1}{2}$ occupied

X 4 position gives heating and max ventilation or fully occupied room.

MAX button. This gives maximum ventilation at high fan speed for 15 minutes only. This is used to refresh the room as quickly as possible. The button must be pressed for a minimum of 2 seconds to operate.

Further information about the operation of the unit, the safety features and how the fans, the damper and the water heating valve are used to control ventilation, heating, free and night cooling are available on request.

CONTROL PAD - HEAT & RECIRCULATION

This is identical to the control pad supplied with the 'Heat & Ventilation' unit, but since there is no fresh air supply the ventilation slider has no effect other than to switch the unit between Normal occupied mode and unoccupied set back mode.

Temperature control is still provided by the set-point adjuster and the control pad incorporates a room air temperature sensor.

OPERATION – Automatic Ventilation or BMS

Figure 12

Controller type: TE/TS/K for manual Temperature & Automatic Ventilation.
Also incorporates a room temperature sensor

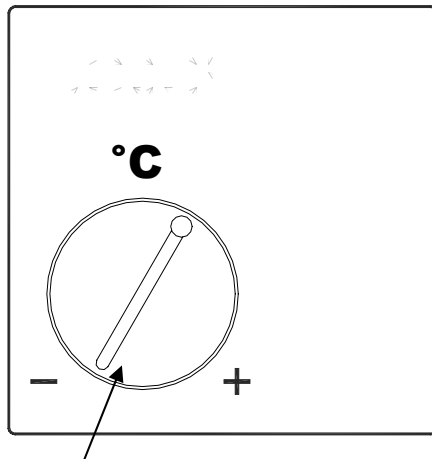

Set point adjuster -
(Shown at approx 24°C)

DO NOT SWITCH UNIT OFF AT THE MAINS except in times of emergency

Unit Functionality:

In this format of operation the unit is effectively switched ON or OFF by the use of an external timer, PIR sensor or BMS. See individual connection information.

All ventilation rates are controlled automatically and there is no manual control. It is usual to have a CO₂ Sensor mounted in the room with this form of control. This limits the quantity of fresh air to just that required for the occupancy of the room for increased energy efficiency. The Sensor can either be supplied as part of the Innovair unit or as part of the BMS control.

If supplied as part of the Innovair Unit See section headed ‘Connection to CO₂ Sensor’ for more information.

Manual adjustment of **Room temperature** is controlled by the set-point adjuster, which can be rotated between the 15°C and the 30°C settings. BMS control can also be used to remotely re-scale the minimum and maximum set point positions (e.g. 18°C min / 20°C max) for increased energy efficiency.

The unit will operate in either **Normal ‘occupied’ operating mode** or **Unoccupied’ set-back mode** as with the Manual / Stand Alone unit.

In this mode unit operates to satisfy the set back temperature or ‘night time cooling requirement only.

MAINTENANCE

ACCESS PANEL

After removing the re-circulation grille access panel the front access panel is secured by two M5 hexagonal head screws concealed behind the re-circulation grille and re-circulation access panel (refer to figure 4).

END PANELS

Each end panel is secured by two 'lugs' which locate into rear slots at the side of the unit and then secured by two M5 hexagonal head screws at the front (refer to figure 4).

FILTER

The filter media is held in a frame, which locates in channel slides behind the re-circulation grille access panel. After removing the re-circulation grille access panel the filter can be withdrawn after undoing the two quarter-turn fasteners and sliding the frame forward.

A vacuum cleaner or gentle beating may be used to clean the filter.

The period between cleaning is dependent on operating conditions. In a very dirty atmosphere the filter will require frequent cleaning (maybe every few weeks) whereas in a clean environment it may only be necessary every few months.

Replacement filter medium is available in 10m rolls for fitting into the frame assembly.

FANS & MOTORS

Providing the filter is regularly cleaned the fans and motors will require no attention. They can be accessed however by removing the re-circulation grille access panel and the main access panel. Clean using a soft brush and vacuum cleaner.

HEATING COIL

Providing the filter is regularly cleaned the heating coil will require little or no attention.

However if the filter is allowed to get very dirty some dust will percolate through and become entrained in the coil. In this case it can be cleaned by removing the front access panel, the discharge grille, the discharge access panel and the coil access panel and applying a jet of air to the air leaving face.

DAMPER AND ACTUATOR

The damper requires no maintenance, other than to brush clean occasionally.

Located on the left hand side of the unit the damper actuator requires no maintenance and should not be removed from its mounting panel.

CASING

The interior of the unit should be cleaned occasionally with a soft brush and a vacuum cleaner.

On cased units periodically check that the paint is in good condition and repaint when necessary.

TOOLS REQUIRED:-

7mm A/F nut spinner

Pozidrive 2pt Screwdriver

UK SALES CONTACTS

NORTH EAST : Ken Embleton

Embleton Enviro. Products Ltd
Gear House, Saltmeadows Road
Gateshead
Newcastle Upon Tyne NE8 3AH
Tel : 0191 490 1155
Fax : 0191 478 5915
Mobile : 07860 828317

NORTH WEST : Graham Gee

4 Bar House Row
Old Pool Bank
Pool in Wharfdale
Yorkshire LS21 1EW
Tel : 0113 284 3269
Fax : 0113 284 3269
Mobile : 07977 981117

MIDLANDS : Roger Parker

184 St Nicholas Park Drive
Nuneaton
Warwickshire
CV11 6EQ
Tel : 02476 347364
Fax : 02476 347364
Mobile : 07831 202567

SOUTH WEST : Steve Rowley

Biddle Air Systems
St. Mary's Road
Nuneaton
Warwickshire CV11 5AU
Tel : 02476 384233
Fax : 02476 373621
Mobile : 07977 981116

SOUTH WALES : Dave Dolling

South Wales Htg Equipment Ltd
98 Holmesdale Street
Grangetown, Cardiff
South Glamorgan CF1 7BU
Tel : 02920 237654
Fax : 02920 237654
Mobile : 07815 833804

SOUTH EAST : Ian Ross

Mobile: 07977 981123

N. IRELAND : Stuart Magee

Sermet (NI) Ltd
11 Lisburn Street
Hillsborough
Co. Down BT26 6AB
Tel : 02892 682531
Fax : 02892 683933

SCOTLAND : Roddy MacDougall

Tel: 01236 738511
Fax: 01236 738511
Mobile: 07977 981126



Biddle Air Systems Limited

*St. Mary's Road, Nuneaton, Warwickshire CV11 5AU
Tel: +44 (0) 2476 384233 Fax: +44 (0) 2476 373621*

Biddle B.V.

*PO Box 15, NL-9288 ZG Kootstertille, The Netherlands
Tel: +31 (0) 512 335555 Fax: +31 (0) 512 331424*

Biddle GmbH

*Emil-Hoffmann-Strabe 55-59, 50996 Koln, Germany
Tel: +49 (0) 2236 380235 Fax: +49 (0) 2236 380239*

Biddle

*48 rue Denis Papin, 94200 Ivry sur Seine, France
Tel: +33 (0) 149 605555 Fax: +33 (0) 149 605556*

Biddle NV

*Business Park E19, Battelsesteenweg 455E, 2800 Mechelen, Belgium
Tel: +32 (0) 15 287676 Fax: +32 (0) 15 287677*