



ForceflowTM
FAN CONVECTOR RANGE

Why Use a Fan Convector?

Widely used in buildings such as schools, libraries, churches, hospitals, leisure centres, shops and offices fan convectors have for many years been universally acknowledged to be one of the simplest and most cost-effective ways of heating a room quickly.

With minimal maintenance requirements, fan convectors are designed to rapidly distribute heat throughout a room whilst occupying much less wall space than a radiator of equivalent output.

Why Use Forceflow 900 Series Fan Convectors?

Biddle has been manufacturing fan convectors for around 50 years, with the Forceflow 900 series being the latest in a long line of market leading designs.

The Forceflow 900 series incorporates:

- non-handed casing, which allows the handing of the unit to be changed on site
- detachable top panel, to create more space for fitting of valves
- removable fan/motor assembly, to give easy access to the back pipe connections
- increased internal space, for speedier installation
- horizontal coil header, to allow fitting of angle valves
- EU3 grade disposable panel filter, to simplify maintenance
- electric heating options

and is also available in:

- LST (low surface temperature)
- CB (condensing boiler)
- low output

variants, all as detailed in separate brochures and data sheets



Contents

Why use Forceflow	1
Styles available	2
Controls and Accessories	3
Dimensions	4-5
Unit weights	5
Engineering Specification	6



Styles Available

The Forceflow fan convector can be mounted almost anywhere on the wall or ceiling - either

- exposed/cased, with integral discharge and return air grilles and bevelled ends or
- concealed/recessed, with discharge and return air spigots, loose grilles and square ends

Pipework connections are manufactured as left or right-hand (when looking at the access panel). The 'handing' can easily be changed on site.

Although the following 21 styles represent the vast majority of installations, many more styles and configurations are available on request. Access is indicated by 'A'.

All the styles are available with a reverse air flow.

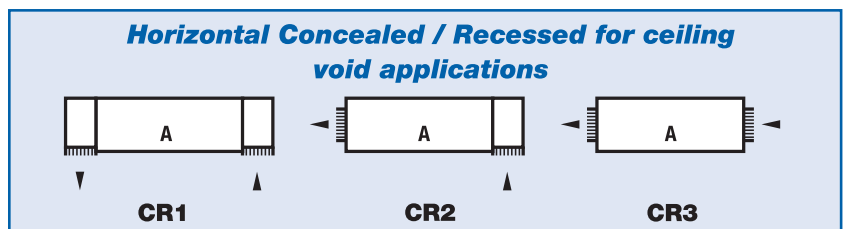
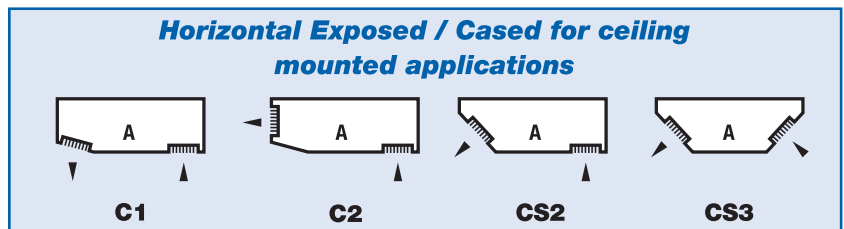
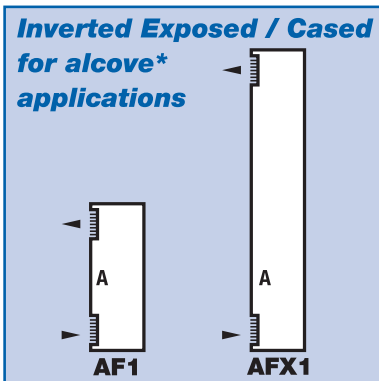
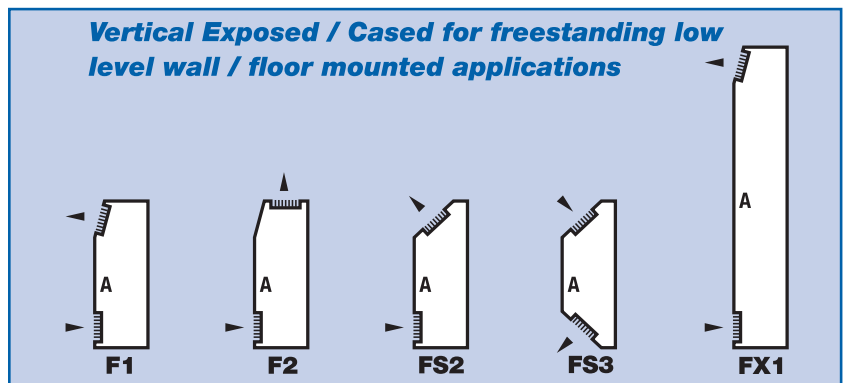
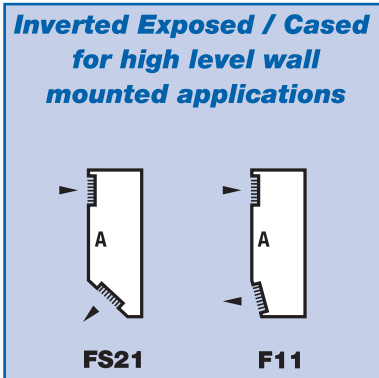

*with bevelled or square ends

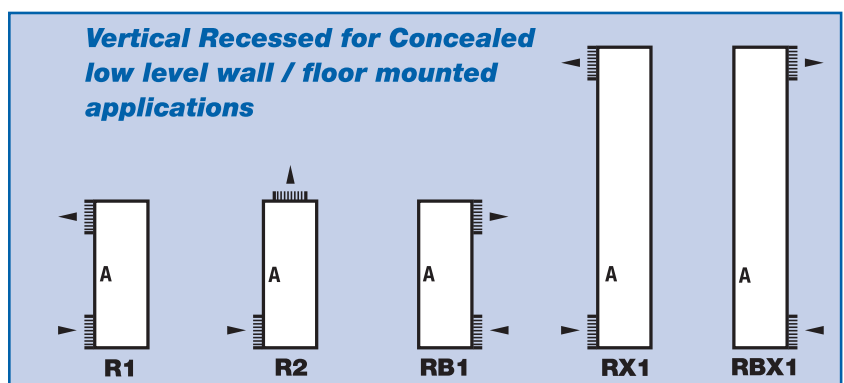

Controls and Accessories

Each Forceflow unit has three fan speeds and is supplied as standard with:

- built-in on/off, fan speed and summer/winter rocker switches
- an on/off (T1) thermostat (see table left)
- a medium/low speed change (T2) thermostat (see table left)
- a low water temperature cut-out (T4) thermostat
- a textured white (RAL9010) paint finish
- an EU3 grade disposable panel filter
- a screw-fixed access panel
- discharge and return air grilles
- horizontal 3/4" BSP female pipe connections

Mounting of Units	On/Off (T1) Thermostat	Speed Change (T2) Thermostat
Vertical-standard air flow	built-in	built-in
Vertical-reverse air flow	remote	remote
Horizontal	remote	remote
Inverted	remote	remote

Further control options and accessories are available, the most popular being:

- remote on/off, fan speed and summer/winter switches
- tamperproof thermostats
- adjustable low water temperature cut-out (T4) thermostat
- pencil proof and finger proof grilles
- group control and fan enable relays
- 100mm high plinth
- lockable access panel
- fresh air spigot with or without motorised damper
- proportional speed controller
- metal framed EU2 grade nylon non-woven filter
- extended air vent
- height extension pieces
- special paint colour

Performance

Each model is available as standard as shown right.

Heating duties are given for LTHW with 82°C flow and 71°C return, and 20°C entering air temperature. External static pressure is 0Pa. Noise levels are for guidance only.

Biddle can advise on performance under different conditions.

When the fans are turned off the natural convective heat emission is approximately 15% of the emission shown at medium fan speed.

Alternative air volumes and heating duties are available. Please advise us if you require further details.

Model	Fan Speed	Air Volume (l/s)	Heating Duty (kW)	Noise Level (NR)	Leaving Air Temp (°C)	Full Load Current (Amps)	Coil Water Pressure Drop (kPa)	Water Flow Rate (kg/s)
915	high	118	4.65	40	53	0.33	0.83	0.10
	medium	87	3.80	35	56	0.28	0.61	0.08
	low	59	3.02	27	62	0.21	0.41	0.07
930	high	190	7.81	41	54	0.49	2.64	0.17
	medium	176	7.32	35	54	0.48	2.10	0.16
	low	104	5.75	25	66	0.43	1.29	0.12
935	high	254	10.50	43	54	0.45	4.75	0.23
	medium	202	9.10	35	57	0.42	3.55	0.20
	low	136	7.08	24	63	0.38	2.49	0.15
940	high	318	14.48	42	58	0.50	10.1	0.31
	medium	249	12.50	35	62	0.43	8.25	0.27
	low	164	9.62	30	69	0.39	4.24	0.21
975	high	465	19.92	46	55	1.70	4.69	0.43
	medium	408	17.90	37	56	0.91	2.64	0.39
	low	250	13.15	29	64	0.74	1.70	0.28

Electric Heating

The 915 model is available in 'F1', 'C1' and 'AF1' styles with single phase electric, rather than LTHW, heating. Electric heated units are supplied with:

- 1.5kW and 3.0kW outputs, regardless of fan speed
- built-in fan speed, output selection and summer/winter switches
- a built-in on/off (T1) thermostat
- a built-in output change thermostat
- a textured white (RAL9010) paint finish
- an EU3 grade disposable panel filter
- a screw-fixed access panel
- discharge and return air grilles

Model	Minimum Water Flow Rate (kg/s)
915	0.025
930	
935	
940	
975	0.045

Dimensions

Vertical Styles

Model	'D'	'W'			
		All Vertical Styles	Exposed / Cased	Alcove (bevelled ends)	Alcove (square ends)
915	207	805	805	750	750
930	207	1055	1055	1000	1000
935	207	1305	1305	1250	1250
940	207	1555	1555	1500	1500
975	250	1805	1805	1750	1750

Style	'H'
F1, F2, FS2, AF1 (with bevelled ends), F11, FS21	660
AF1 (with square ends)	600
FS3#	810
FX1, AFX1	1850
R1, R2, RB1	600
RX1, RBX1*	1850

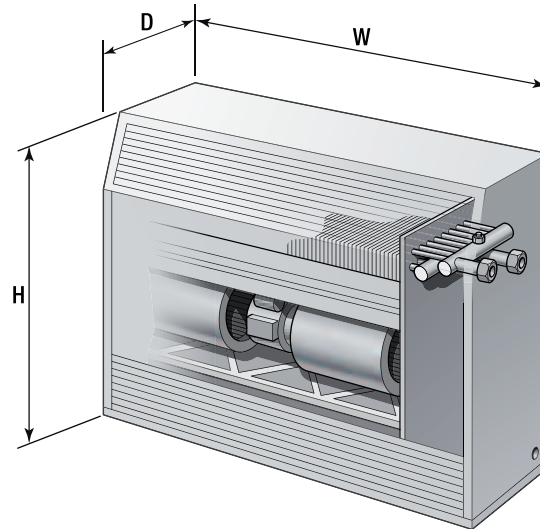

The FS3 style is not available as a model 975 *The RBX1 is available as a Telescopic unit, with a site adjustable height

Horizontal Styles

Model	'H'		'W'	
	All Horizontal Styles (except CR1, CR2)	CR1 & CR2	Exposed / Cased	Concealed/ Recessed
915	207	290	805	750
930	207	290	1055	1000
935	207	290	1305	1250
940	207	290	1555	1500
975	250	333	1805	1750

Style	'L'
C1, C2, CS2	660
CS3#	810
CR3	600
CR2	743
CR1	886

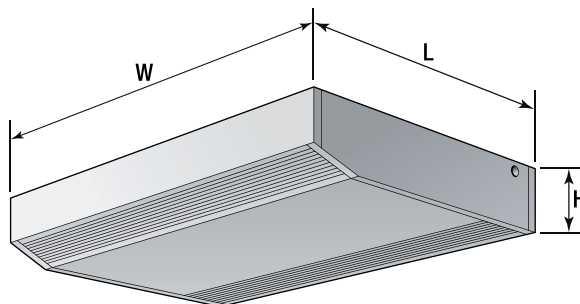

The CS3 style is not available as a model 975

Pipe Connections Rc 3/4 (3/4" BSP external)

Model	'D'	'G'	'J'	
			Exposed / Cased	Concealed/ Recessed
915	207	64	158	130
930	207	64	158	130
935	207	64	158	130
940	207	64	158	130
975	250	86	158	130

Standard pipe entry is through the base, apart from CR1, CR2 and CR3 style units when pipe entry is through the side.

If required, pipe entry through the top may be available on some styles.

The flow header connection should be on the air leaving side of the coil

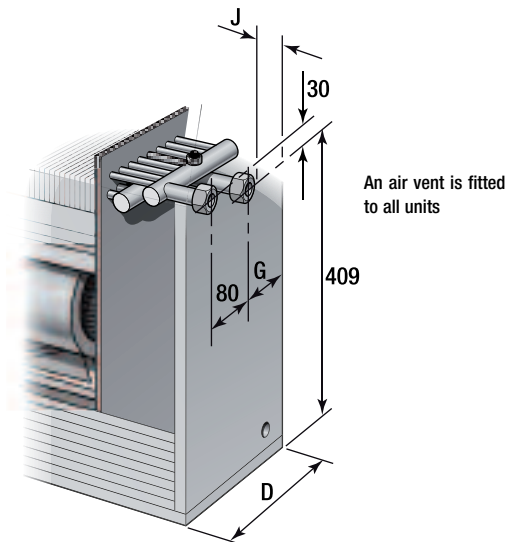

Dimensions

Fixing Centres - 9mm key holed slots

Style	A	B	C	F
F1, F2, FS2, AF1, F11, FS21, C1, C2, CS2	50	540	70	87
R1, R2, RB1, CR1, CR2, CR3	35	530	35	60
FX1, AFX1	50	1190	70	87
FS3, CS3	50	670	90	87

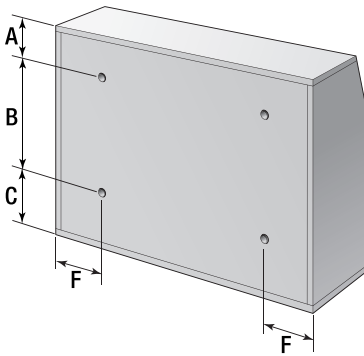

Style	A	B	C	D	E	F
RX1, RBX1	183	900	202	530	35	60

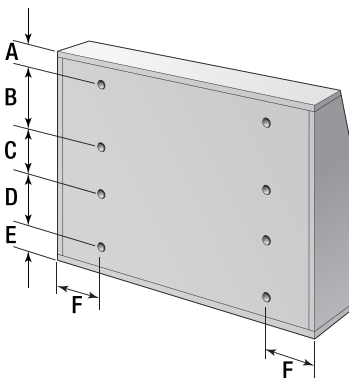

Unit Weight

Unit	915	930	935	940	975
Approx. operating weight kg units 600 or 660mm high	29	39	45	52	66
Approx. operating weight kg units 1850mm high	49	65	75	88	109

Spigot & Grille Details

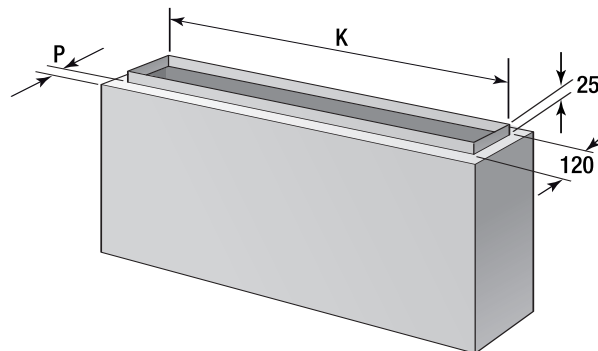
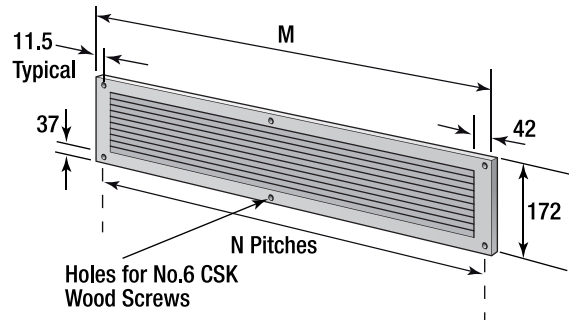
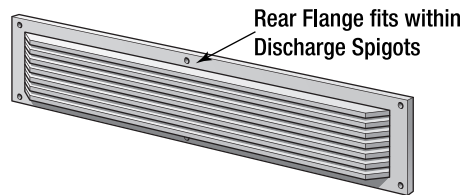
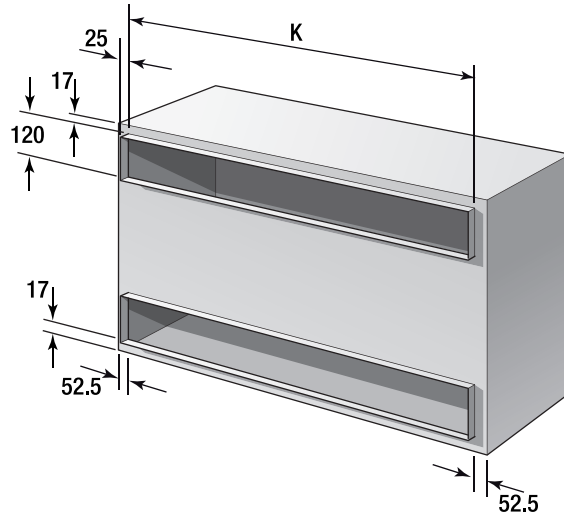

Model	K	M	N	P
915	645	704	2x340.5	43.5
930	895	954	2x465.5	43.5
935	1145	1204	2x590.5	43.5
940	1395	1454	3x477.0	43.5
975	1645	1704	3x560.3	65.0

Engineering Specifications

The Forceflow 900 series fan convectors, as manufactured by Biddle Air Systems Limited, incorporate materials and components to the following specification:



Casing: Manufactured from 20 gauge zinc coated sheet steel, welded together and stiffened to form a rigid structure preventing distortion and drumming. The screw-fixed top panel is removable to provide ease of access for fitting of valves. The detachable access panel is secured to the casing by two countersunk screws or, if requested, by two key operated locks. When the access panel is removed the cabinet can withstand, without permanent deformation, a 90kg load placed over an area of 300mm x 200mm in the centre of the top panel.

Finish: The metal case is treated prior to finishing in a textured epoxy polyester powder paint, RAL 9010 (white).

Grilles: Integral and loose grilles are of a linear pattern, with 70% free area and a minimum material thickness of 2.2mm, manufactured from extruded aluminium, treated and finished in a textured epoxy polyester powder paint, RAL 9010 (white).

Filter: Fitted on the return air side of the fan(s) the cardboard framed panel is removable via the front of the unit, once the access panel has been removed, and is manufactured from EU3 grade nylon type material.

Plinth: With fixing for walls with and without skirting board, plinths are manufactured from 20gauge zinc coated sheet steel, treated and finished in a textured epoxy polyester powder paint, RAL 9010 (white).

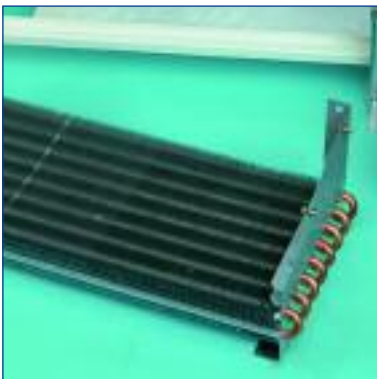

Heat Exchanger: Leak tested to 30bar and with maximum operating conditions of 121°C flow 10bar, the heat exchangers are of a two row configuration with aluminium fins expansion bonded to copper primary tubes, brazed in turn to copper headers with a 1/8" BSP air vent.

Pipe Connections: 3/4" BSP female horizontal flow and return connections, handed when viewing the face of the unit with the access panel. Standard handing is right-hand side (see adjacent picture), but this can easily be changed on site without the need for any new components or brackets.

Fan/Motor Assembly: Screw fixed to guide rails and easily removable for maintenance purposes without disturbing any wiring.

Motors: Suitable for use with a 240v, 1ph, 50Hz mains power supply, of the multi-tapped permanent capacitor induction type, being totally enclosed and with a built-in self-resetting thermal overload cut-out.

Fans: Balanced double inlet double width centrifugal type, with forward curved blades and metal impellers, and directly mounted onto the motor shaft.

Wiring: Factory and site wiring of thermostats and switches is via a fused electrics box fitted within the unit at the opposite end to the pipe connections.

Packaging: Each fan convector shall be despatched in a purpose-made cardboard box, or shrink-wrapped with polystyrene protection, which will be marked with unit details.

CE Marking: The fan convector shall comply with all currently relevant EU directives.



biddle

- Biddle Air Systems Limited
St. Mary's Road, Nuneaton
Warwickshire CV11 5AU

Tel: +44 (0)24 7638 4233
Fax: +44 (0)24 7637 3621
Email: sales@biddle-air.co.uk
<http://www.biddle-air.co.uk>

- Biddle B.V.
P.O. Box 15
NL-9288 ZG Kootstertille
The Netherlands

Tel: +31 (0)512 335555
Fax: +31 (0)512 331424

- Biddle GmbH
Emil - Hoffmann - Straße 55-59
50996 Köln
Germany

Tel: +49 (0)2236 96900
Fax: +49 (0)2236 969010

- Biddle
21 Allée de Vendanges
77183 Croissy Beaubourg
France

Tel: +33 (0) 1 64 11 15 55
Fax: +33 (0) 1 64 11 15 66

- Biddle NV
Business Park E19
Battelsesteenweg 455E
2800 Mechelen
Belgium

Tel: +32 (0) 15 287676
Fax: +32 (0) 15 287677



biddle
CLIMATE SOLUTIONS



The information given in this brochure is, to the best of our knowledge, correct at the time of going to print. However, Biddle Air Systems are constantly looking at ways of improving their products and services and therefore reserve the right to change without prior notice any of the data contained in this publication.
12.08