

Now  
available with  
EC/DC Fans  
and controllable  
Fresh Air Damper

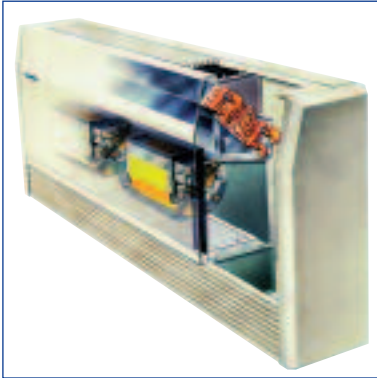

**Isotherm**<sup>TM</sup>  
ADVANCED TECHNOLOGY FAN COILS

## ***Advanced Technology Fan Coils Creating New Standards in Individual Climate Control***



### ***Contents***

New Generation of Fan Coils	1
Features and Benefits	2
Performance and Selection	3
Key Dimensions	4
Electrical Data	5
Model References	5
Materials, Components and Specifications	6

The Isotherm range of fan coils, from Britain's leader in individual climate control, has now been proven over the last decade to deliver high performance in the most demanding working environments.

By rigorously testing the components - motors, fans, controls, valves, filters, coils, grilles, discharge plenums - Biddle developed a high reliability, high specification fan coil which produces a higher thermal output at a given air volume and noise level.

The full spectrum of performance and application requirements is met with four chassis and four cased unit sizes, all available in horizontal and vertical configurations.

### ***EC/DC Fans***

Now, with the impact of the latest Building Regulations Part L2A on energy efficiency and carbon emissions Isotherm is available not just with 4-pole AC fan motors (which produce specific fan powers of circa 0.5W/ls<sup>-1</sup>) but also with the latest EC/DC fan motors (which produce specific fan powers of circa 0.2 W/ls<sup>-1</sup>).

### ***Controllable Fresh Air Damper***

And for applications where fresh air is introduced to the fan coil from a central air handling unit, the traditional volume control damper in the ductwork can now be replaced with an Isotherm unit incorporating its own integral fresh air damper to more efficiently control the recirculation and fresh air volumes.



### ***Low Noise and Long-life***

The key to low noise, trouble-free performance lies in Isotherm's exceptionally quiet fan/motor specification combined with an acoustically-lined integral inlet plenum section. Double-inlet, double-width centrifugal fans incorporate built-in direct drive motors with advanced anti-vibration mountings and "sealed for life" bearings capable of more than 40,000 running hours. All units are acoustically and thermally lined to further enhance their smooth and quiet operation.

### ***Top Quality Construction and Finish - RAL 9010***

With Isotherm, Biddle has laid down new standards in robust construction and finish quality. All unit casings are fabricated from high strength zinc plated steel to a unique Biddle design specifically to eliminate the risk of deformation and vibration. Both chassis and cased versions are finished to the highest standard using controlled electrostatic powder coating techniques. (RAL 901).

### ***Clean Air Filtration***

Isotherm comes ready-fitted with an easily removable filter (Class EU2) to ensure airflow output is continuously filtered for maximum comfort. This filter medium is easily cleaned and accessed without the need for tools or the removal of any panels. Filters are produced in 25mm thick individual and disposable cartridges which are removable via any existing ceiling grid.

### ***Unique Drain Tray Specification***

The horizontal chassis unit is fitted with a purpose-designed polymeric-based, fire retardant (flammability rating UL 94/V-0) drain tray designed to be easily removed for cleaning on-site to meet high health and safety standards. All drain trays extend below the cooling valves.



## Performance and Selection

### Maximum Performance Tables - K3 H1 or K3 HE Coil Arrangement

Unit Size	Speed	NR Guide	Airflow l/s	Sensible Cooling kW	Total Cooling kW	LPHW Heating kW	Optional Electric Heating kW
<b>1</b>	1 (240v)	39	178	2.30	2.75	4.30	1 or 2kW
	2 (210v)	35	162	2.10	2.55	4.10	1 or 2kW
	3 (170v)	33	125	1.75	2.15	3.50	1 or 2kW
	4 (160v)	30	116	1.65	2.05	3.35	1 or 2kW
	5 (150v)	29	101	1.45	1.85	3.00	1 or 2kW
	6 (120v)	24	62	1.00	1.35	2.20	1 or 2kW
<b>2</b>	1 (240v)	40	299	3.85	4.60	6.90	1, 2 or 3kW
	2 (210v)	39	281	3.60	4.30	6.60	1, 2 or 3kW
	3 (170v)	35	233	3.00	3.60	5.90	1, 2 or 3kW
	4 (160v)	34	214	2.85	3.45	5.60	1, 2 or 3kW
	5 (150v)	33	196	2.60	3.15	5.30	1, 2 or 3kW
	6 (120v)	27	133	1.90	2.40	4.20	1, 2 or 3kW
<b>3</b>	1 (240v)	43	426	6.10	7.65	10.30	1, 2 or 3kW
	2 (210v)	39	401	5.80	7.25	9.90	1, 2 or 3kW
	3 (170v)	37	338	4.95	6.25	9.00	1, 2 or 3kW
	4 (160v)	35	314	4.55	5.75	8.60	1, 2 or 3kW
	5 (150v)	34	291	4.25	5.40	8.20	1, 2 or 3kW
	6 (120v)	29	192	2.90	3.80	6.30	1, 2 or 3kW
<b>4</b>	1 (240v)	44	519	7.70	9.90	12.30	1, 2 or 3kW
	2 (210v)	40	484	7.30	9.50	11.85	1, 2 or 3kW
	3 (170v)	38	423	6.60	8.60	10.95	1, 2 or 3kW
	4 (160v)	37	403	6.30	8.20	10.65	1, 2 or 3kW
	5 (150v)	35	376	5.90	7.80	10.25	1, 2 or 3kW
	6 (120v)	30	277	4.40	5.80	8.45	1, 2 or 3kW

### Maximum Performance Tables - K4 H0 or K4 HE Coil Arrangement

Unit Size	Speed	NR Guide	Airflow l/s	Sensible Cooling kW	Total Cooling kW	LPHW Heating kW	Optional Electric Heating kW
<b>1</b>	1 (240v)	39	178	2.55	3.20	N/A	1 or 2kW
	2 (210v)	35	162	2.35	3.00	N/A	1 or 2kW
	3 (170v)	33	125	1.90	2.45	N/A	1 or 2kW
	4 (160v)	30	116	1.80	2.35	N/A	1 or 2kW
	5 (150v)	29	101	1.60	2.15	N/A	1 or 2kW
	6 (120v)	24	62	1.10	1.50	N/A	1 or 2kW
<b>2</b>	1 (240v)	40	299	4.30	5.45	N/A	1, 2 or 3kW
	2 (210v)	39	281	4.05	5.15	N/A	1, 2 or 3kW
	3 (170v)	35	233	3.40	4.30	N/A	1, 2 or 3kW
	4 (160v)	34	214	3.15	4.05	N/A	1, 2 or 3kW
	5 (150v)	33	196	2.90	3.70	N/A	1, 2 or 3kW
	6 (120v)	27	133	2.10	2.75	N/A	1, 2 or 3kW
<b>3</b>	1 (240v)	43	426	6.85	9.10	N/A	1, 2 or 3kW
	2 (210v)	39	401	6.45	8.60	N/A	1, 2 or 3kW
	3 (170v)	37	338	5.50	7.35	N/A	1, 2 or 3kW
	4 (160v)	35	314	5.00	6.80	N/A	1, 2 or 3kW
	5 (150v)	34	291	4.70	6.30	N/A	1, 2 or 3kW
	6 (120v)	29	192	3.15	4.25	N/A	1, 2 or 3kW
<b>4</b>	1 (240v)	44	519	8.65	11.70	N/A	1, 2 or 3kW
	2 (210v)	40	484	8.15	11.00	N/A	1, 2 or 3kW
	3 (170v)	38	423	7.20	9.90	N/A	1, 2 or 3kW
	4 (160v)	37	403	6.85	9.40	N/A	1, 2 or 3kW
	5 (150v)	35	376	6.45	8.85	N/A	1, 2 or 3kW
	6 (120v)	30	277	4.80	6.60	N/A	1, 2 or 3kW

**NOTES:**

1. Performance figures based upon 30 Pa external resistance, Chilled Water 6/12°C, Cooling E.A.T. 23°C/50% RH, LPHW 82/71°C, Heating E.A.T. 21°C.

2. NR figures are based upon the horizontal chassis unit (casing style H3) mounted above a suspended ceiling and are for guidance only.

For other casing styles namely V3, F1, F2 & C2 please contact the Biddle sales office.

We strongly recommend that particular noise levels are calculated for each application using the sound power levels made available upon request.

## Key Dimensions

### Standard Discharge Plenums

Size	Spigot Detail
A1	3 x $\phi$ 200
A2	3 x $\phi$ 200
A3	4 x $\phi$ 200
A4	5 x $\phi$ 200

### General Unit Dimensions

Size	'L'
A1	915
A2	1165
A3	1665
A4	1890

### Horizontal Chassis - Style H3

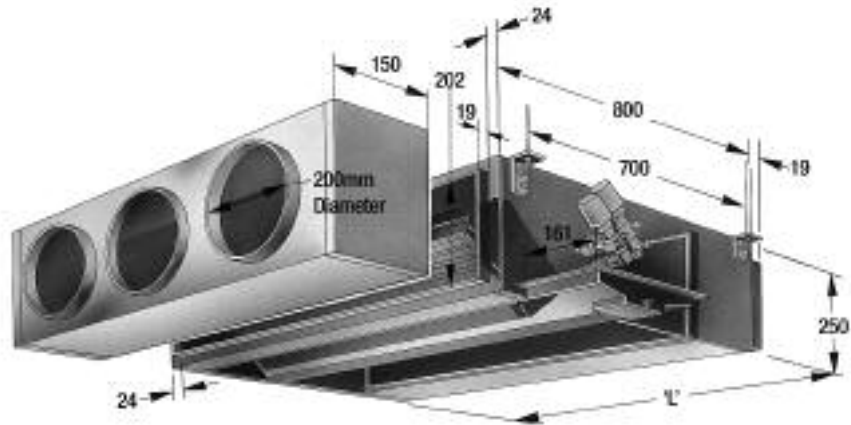

### Vertical Chassis - Style V3

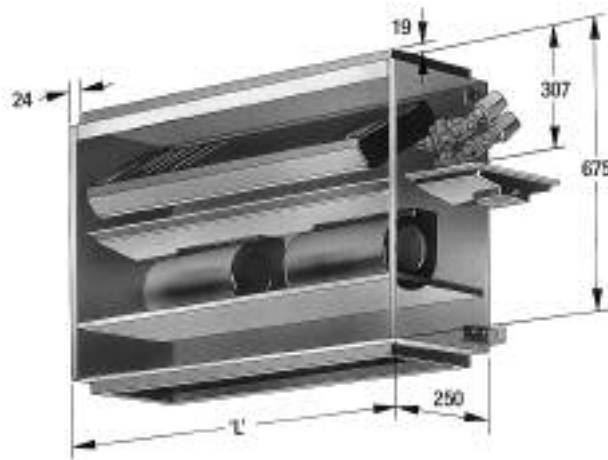

### General Unit Dimensions

Size	'L'
A1	915
A2	1165
A3	1665
A4	1890

### Cased Options - Style F1, F2 or C2

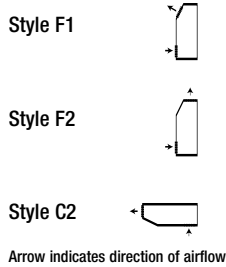

### General Unit Dimensions

Size	'L'
B1	1185
B2	1435
B3	1935
B4	2160



## Electrical Data

### Wiring Diagram

General schematic for chassis and cased units (does not include electrical heating options).

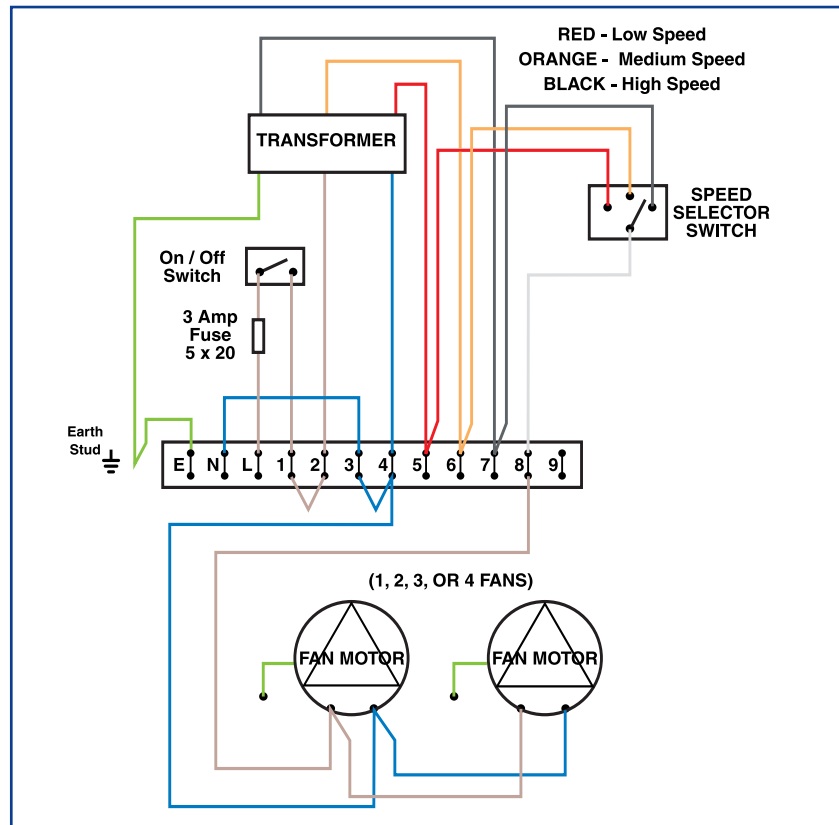

Note: Specific wiring diagrams are available from Biddle sales office.

### Model References

The model reference consists of a code giving unit size, coil and casing arrangement.

Example:

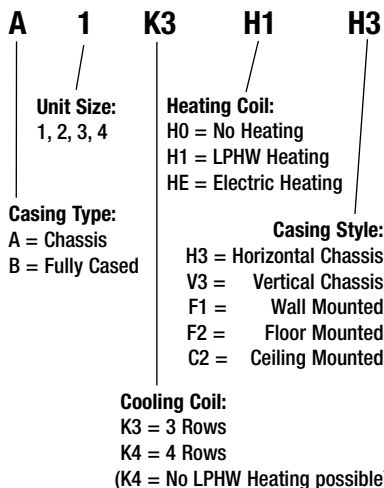

### Electrical Loads

Model Size		Speed					
		1	2	3	4	5	6
1	Full Load Current (A)	0.5					
	Voltage	240	210	170	160	150	120
	Absorbed Power (W)	110	93	72	69	65	45
2	Full Load Current (A)	1.0					
	Voltage	240	210	170	160	150	120
	Absorbed Power (W)	195	161	120	112	107	74
3	Full Load Current (A)	1.5					
	Voltage	240	210	170	160	150	120
	Absorbed Power (W)	277	230	175	165	148	110
4	Full Load Current (A)	2.0					
	Voltage	240	210	170	160	150	120
	Absorbed Power (W)	356	296	220	205	186	138

The above figures are for guidance only and accurate electrical data can be obtained (along with computer selections) from our sales office at Nuneaton.

## **Materials, Components and Specifications**

### **Unit Casing and Panels:**

Fabricated from galvanically protected sheet steel (Zintec) to which a white (RAL 9010), lightly textured electrostatic powder coating has been applied.

The unit casing is thermally/acoustically lined with a melamine based, sound absorbent 12mm thick foam conforming to Class 0 fire specification to British Building Regulations, flammability rating UL 94/V-0.

Construction design provides maximum structural strength thus preventing the risk of deformation and eliminating vibration. The chassis/case covers all internal components whilst allowing easy side access to valve/control units and all components.

### **Inlet/Outlet Plenum:**

The chassis unit is supplied with acoustically lined, built-in intake plenum ready-fitted to minimise intake noise. Optional discharge plenums can be supplied with 3, 4 or 5 circular spigots for fitting to standard ducting arrangements. Auxiliary electric heating is located in an additional plenum section 100mm long.

### **Fans and Motors:**

Each unit has double-inlet, double-width centrifugal fans complete with built-in direct drive motor complete with integral thermal protection. The high specification motors incorporate “sealed for life” bearings and are anti-vibration mounted to give an expected life in excess of 40,000 running hours. Both 4-pole AC & EC/DC options are available.

### **Coils:**

Each coil is expertly constructed from copper tubes with mechanically bonded high grade aluminium fins. Coils are pre-tested in the factory to 10 bar (gauge) pressure and are available in up to four rows for two or four pipe applications.

### **Electrical Data:**

The table opposite indicates nominal voltage, amperage and power (watts) ratings for each speed setting.

### **Filter:**

Each unit incorporates slide-out fire retardant, 25mm thick replaceable filters (Class EU2), fitted in a disposable holding frame. Filters are easily accessed from the front of the unit without removing any panels and through any ceiling grid where access is restricted.

### **Control Systems:**

The Isotherm system is designed for optimum efficiency using the Biddle supplied control package - valves, actuators, controllers, six step/branch transformer and sensor. Where necessary, customer specified control packages can be factory-fitted. On all chassis units the controls package is mounted within a purpose made box, situated at the opposite end to pipework connections.

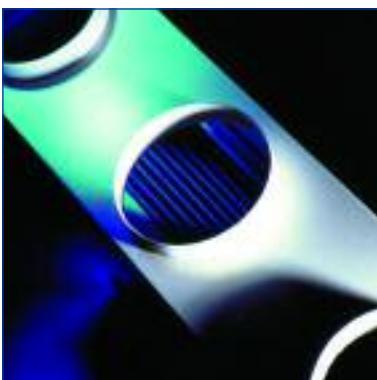

# biddle

- Biddle Air Systems Limited  
St. Mary's Road, Nuneaton  
Warwickshire CV11 5AU

Tel: +44 (0)24 7638 4233  
Fax: +44 (0)24 7637 3621  
Email: [sales@biddle-air.co.uk](mailto:sales@biddle-air.co.uk)  
<http://www.biddle-air.co.uk>

- Biddle B.V.  
P.O. Box 15  
NL-9288 ZG Kootstertille  
The Netherlands

Tel: +31 (0)512 335555  
Fax: +31 (0)512 331424

- Biddle GmbH  
Emil - Hoffmann - Straße 55-59  
50996 Köln  
Germany

Tel: +49 (0)2236 96900  
Fax: +49 (0)2236 969010

- Biddle  
21 Allée de Vendanges  
77183 Croissy Beaubourg  
France

Tel: +33 (0) 1 64 11 15 55  
Fax: +33 (0) 1 64 11 15 66

- Biddle NV  
Business Park E19  
Battelsesteenweg 455E  
2800 Mechelen  
Belgium

Tel: +32 (0) 15 287676  
Fax: +32 (0) 15 287677



**biddle**  
CLIMATE SOLUTIONS



The information given in this brochure is, to the best of our knowledge, correct at the time of going to print. However, Biddle Air Systems are constantly looking at ways of improving their products and services and therefore reserve the right to change without prior notice any of the data contained in this publication.  
9.08